



**DIPLOMATIC  
HYDRAULICS**

95 220/103 ED



# FPM

## MEDIUM PRESSURE FILTER FOR LINE MOUNTING

### SERIES 10

**p** max 210 bar

**Q** max (see performance ratings table)

#### OPERATING PRINCIPLE

Filter body

Filter element

- The FPM filters are designed to be line-mounted with BSP threaded ports for hydraulic connections. Threaded holes are machined on the head for possible filter bracket fixing.
- The replacement of the filter element can be easily carried out by using a normal hexagon spanner to unscrew the bowl of the filter, which has a suitably shaped end.
- FPM filters are designed to be installed on medium pressure lines up to 210 bar; the filter elements are made of high efficiency filtering materials and are available with three different filtration degrees:
  - F05 = 5  $\mu\text{m}$  absolute ( $\beta_5 > 100$  - NAS 1638 class 6)
  - F10 = 10  $\mu\text{m}$  absolute ( $\beta_{10} > 100$  - NAS 1638 class 7)
  - F25 = 25  $\mu\text{m}$  absolute ( $\beta_{25} > 100$  - NAS 1638 class 8)
- The filters are always supplied with a by-pass valve.
- The filter elements are available in the standard version (S) or in the long-lasting version (L) is able to hold high quantities of contamination material. For all filter elements the collapsing differential pressure is 20 bar.
- All the FPM filters are designed to incorporate a visual-differential or a visual-electric clogging indicator to be ordered separately (see par. 5).

#### TECHNICAL SPECIFICATIONS

Filter code	BSP ports dimensions	Mass [kg]		Rated flow (indicative) [l/min]					
		type S	type L	F05S	F05L	F10S	F10L	F25S	F25L
FPM - TB012	1/2"	1,5	2,0	25	40	35	50	45	60
FPM - TB034	3/4"			35	50	50	65	65	80
FPM - TB100	1"			40	60	60	85	85	100

**NOTE 1:** The flow rates stated in the table correspond to a 0.8 bar pressure drop measured with mineral oil of viscosity 36 cSt at 50°C.  
As for a different viscosity range, see NOTE 2 - par. 2.2.

Maximum operating pressure	bar	210
Collapsing differential pressure of the filter element	bar	20
Differential pressure for the opening of the by-pass valve (+/- 10 %)	bar	6
Ambient temperature range	°C	-25 ÷ +50
Fluid temperature range	°C	-25 ÷ +110
Fluid viscosity range	cSt	2,8 ÷ 380

#### HYDRAULIC SYMBOL

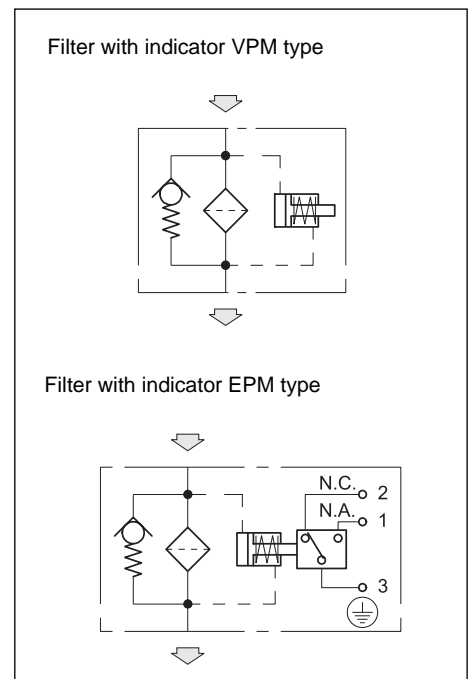



### 1 - IDENTIFICATION CODE

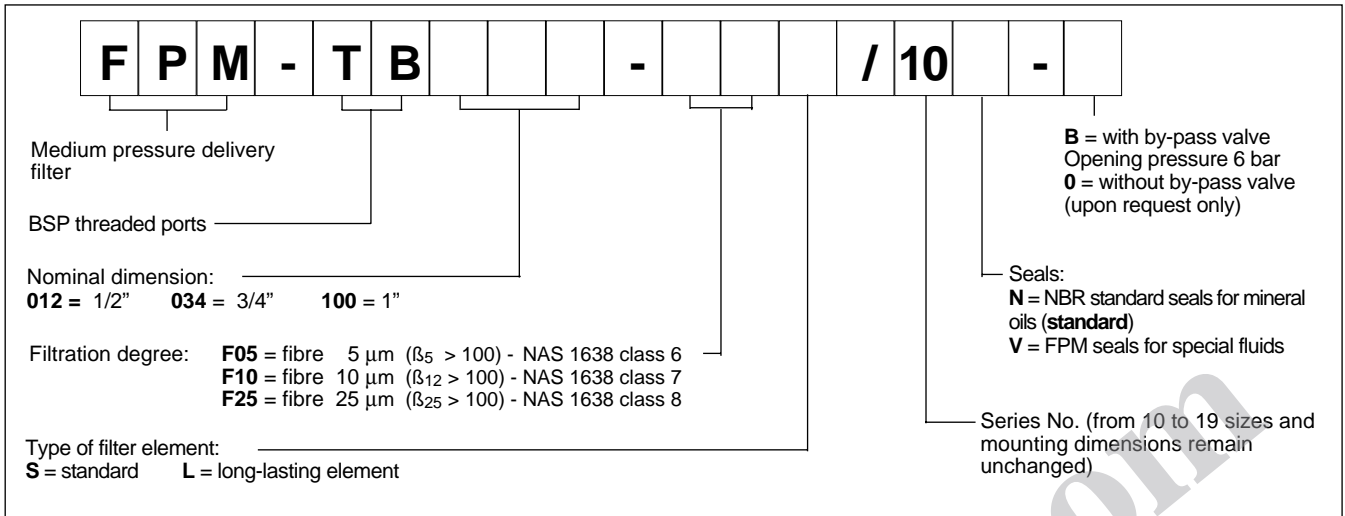

### 2 - CHARACTERISTIC CURVES (values measured with viscosity of 36 cSt at 50°C)

#### 2.1 - Pressure drops through the filter body

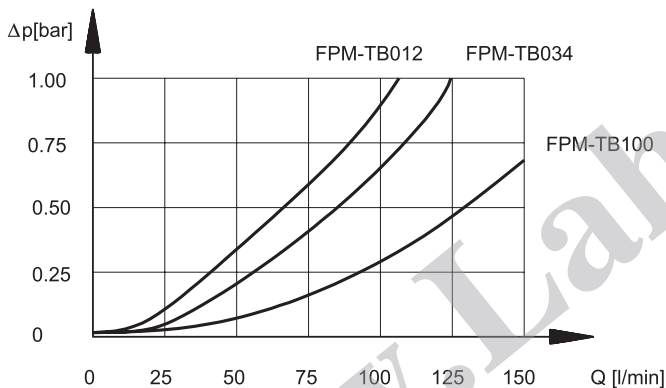

#### 2.2 - Pressure drops through FPME filter element

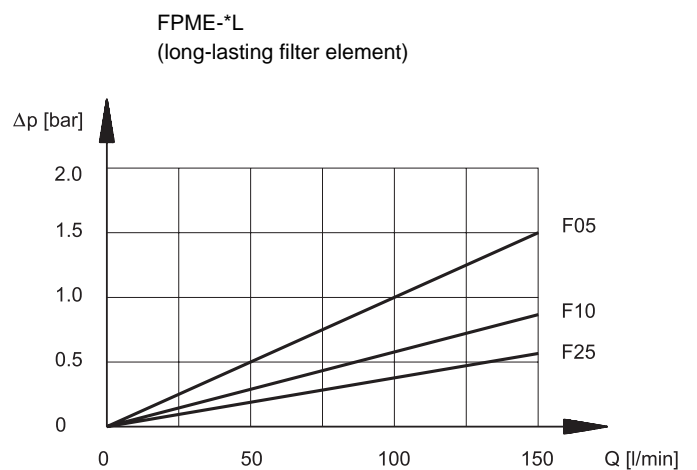
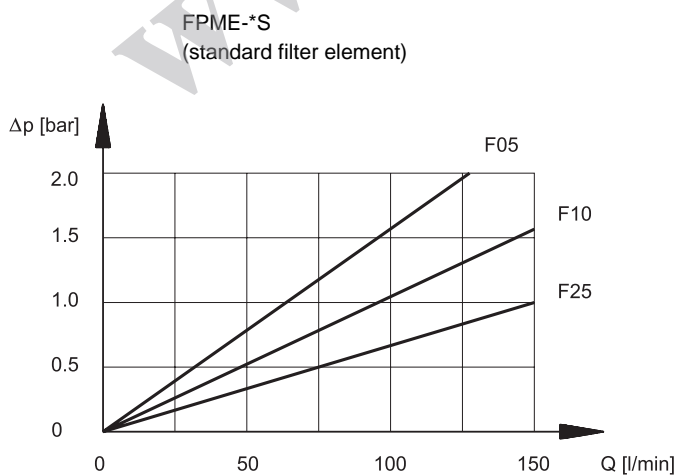



**NOTE 2: The filter size has to be selected so that with the nominal flow rate the pressure drop is lower than 0.8 bar.**

The total pressure drop through the filter is given by adding the body pressure drop values to those of the filter element.

As for fluids whose viscosity degree at a specific operating pressure is different from 36 cSt, the filter total pressure drop has to be changed according to the following ratio:

$$\text{total } \Delta p \text{ value} = \text{body } \Delta p \text{ value} + (\text{real } \Delta p \text{ value of the filter element} \times \text{real viscosity value (cSt)} / 36)$$

$$\text{real } \Delta p \text{ value of the filter element} = \text{value obtainable through the diagrams in par. 2.2}$$

Such ratio is valid for a viscosity value up to 200 cSt.

For a higher viscosity please consult our technical department.

### 2.3 - Pressure drops through by-pass valve

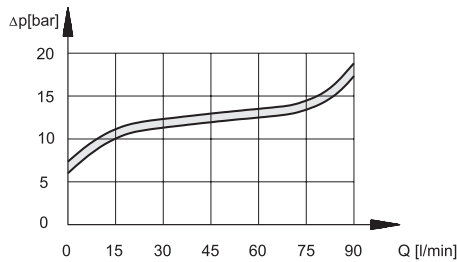

### 3 - HYDRAULIC FLUIDS

Use mineral oil-based hydraulic fluids type HL and HLP according to ISO 6743/4.

For use with other types of fluids such as HFA, HFB, HFC, HFD, please consult our Technical Department.

### 4 - OVERALL AND MOUNTING DIMENSIONS

dimensions in mm

Filter code	D1	H1	H2	R*
FPM-TB012-*S	1/2"	198	104	100
FPM-TB034-*S	3/4"	198	104	100
FPM-TB100-*S	1"	198	104	100
FPM-TB012-*L	1/2"	291	197	100
FPM-TB034-*L	3/4"	291	197	100
FPM-TB100-*L	1"	291	197	100

R\* = Filter element removal space

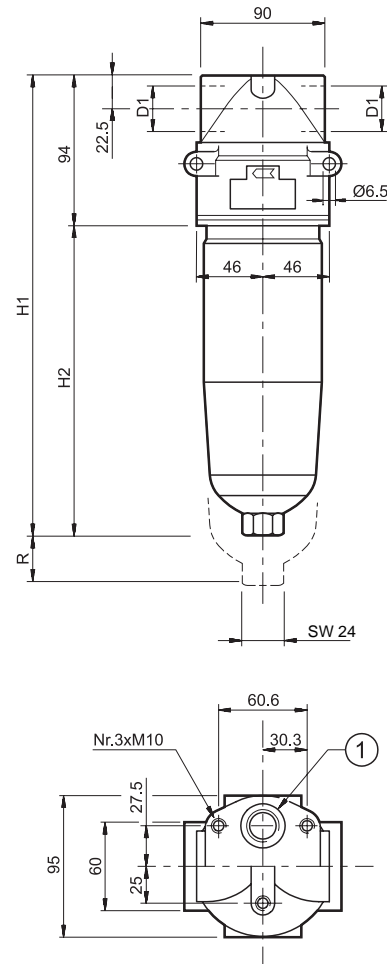

1	Clogging indicator port: M20 x 1,5
---	---------------------------------------



### 5 - CLOGGING INDICATORS

The filters are all designed to incorporate clogging indicators, which have to be ordered separately.

#### 5.1 - Visual indicator for medium pressure delivery filters

Identification code: VPM/10

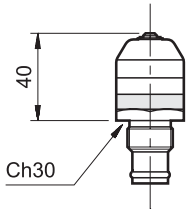

This indicator measures the differential pressure between the filter input and output.

The indicator is supplied with coloured bands, which informs you about the clogging condition of the filter element:

GREEN: efficient filter element  $\Delta p < 5 \text{ bar}$  ( $\pm 10\%$ )

RED: the filter element has to be replaced  $\Delta p > 5 \text{ bar}$  ( $\pm 10\%$ )

#### 5.2 - Electric-visual indicator for medium pressure delivery filters

Identification code: EPM/10

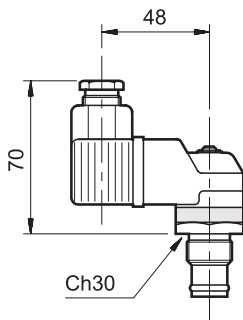

This indicator, apart from giving a visual indication, for example the VPM model, operates by switching an electric contact when the filter element has reached the clogging limit.

The contact can be wired in an open or closed condition (see the hydraulic symbol).

#### TECHNICAL SPECIFICATIONS

Differential operating pressure	bar	5
AC power supply		
Max operating voltage	VCA	250 50/60 Hz
Max load on the contacts (inductive or resistive)	A	5
DC power supply		
Max operating voltage	VCC	125
Max. load on the contacts	A	2 - 0,5 - 0,25 - 0,2
- resistive (with V at 30-50-75-125 VDC)		2 - 0,5 - 0,25 - 0,03
- inductive		
Electric connector	DIN 43650	
Class of protection according to IEC 144 Atmospheric agents	IP65	

### 6 - FILTER ELEMENTS

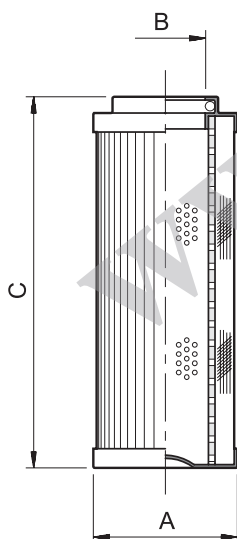

#### FILTER ELEMENT IDENTIFICATION CODE

**F P M E - / 10**

Filter element for FPM filters

Filtration degree: **F05** = fibre 5  $\mu\text{m}$   
**F10** = fibre 10  $\mu\text{m}$   
**F25** = fibre 25  $\mu\text{m}$

Filter element type:

**S** = standard  
**L** = long-lasting

**N** = NBR seals for mineral oils (standard)  
**V** = FPM seals for special fluids upon request

Series No. (from 10 to 19 sizes and mounting dimensions remain unchanged)

Filter element code	$\varnothing A$	$\varnothing B$	C	Average filter surface [cm <sup>2</sup> ]
FPME-*S	52	23,5	115	975
FPME-*L	52	23,5	210	1830